

2

1

B

B

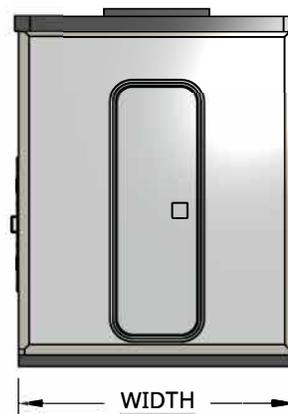
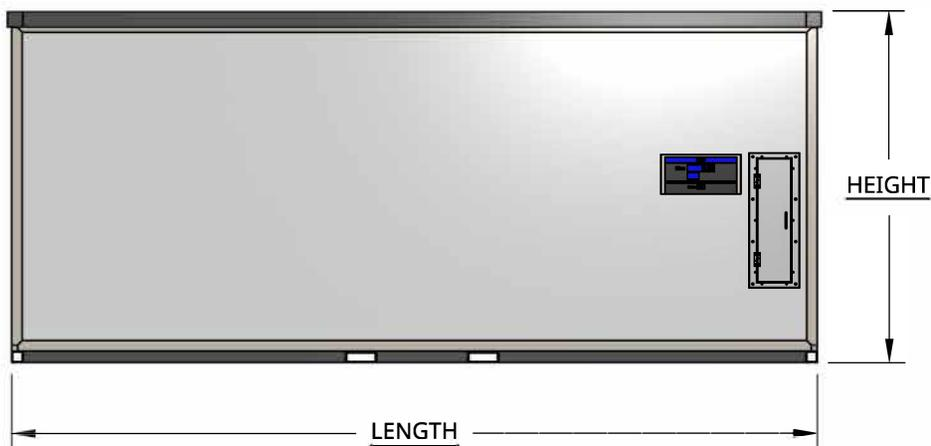
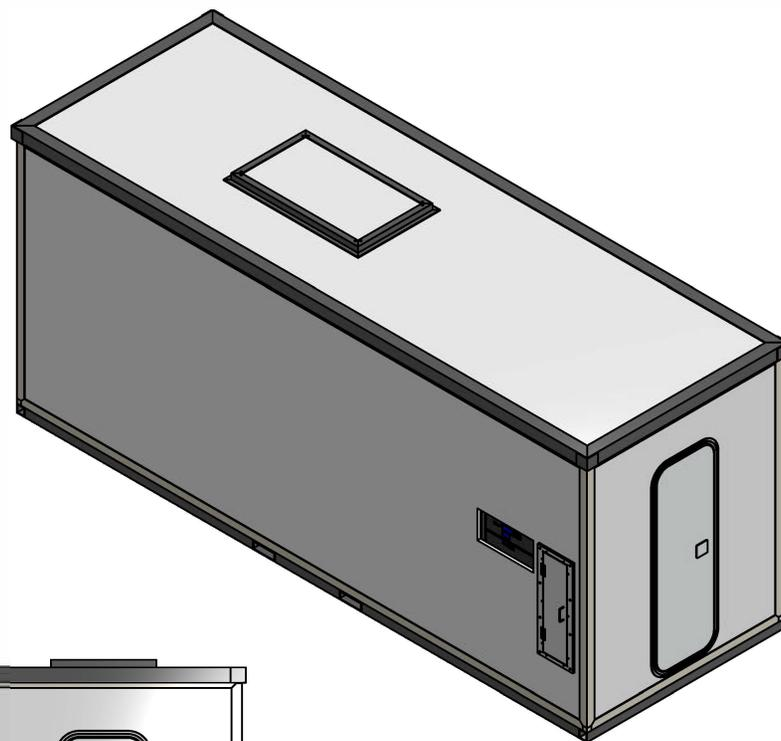

A

A

TANK OPTIONS			
TANK SIZE	LENGTH (IN)	WIDTH (IN)	HEIGHT (IN)
2000G	211	73	92
3400G	210	93	106
5000G	227	100	116
6000G	229	110	119



PROJECT				3RD PARTY W&M WIDE	
DWG. EXTERNAL DIMENSIONS					REV
DWG. NO. SD-PLT-3WM-S2		DRAWN TL	REV DATE 06/28/2022		001
SCALE NTS	SIZE A	SHEET		1 OF 2	

2

1

30/50 AMP ELECTRICAL DISCONNECT

ELECTRICAL PANEL

- ELECTICAL CONTROL UNIT:
- INVENTORY LEVEL GAUGE
  - OVERFILL ALARM & SILENCER
  - [LOW LEVEL WARNING LIGHT]

LEVEL SENSOR

2" FNPT SPARE BULKHEAD

VENTED MANWAY LID

[OVERFILL PREVENTION VALVE]

[DEF FILTER]

2" FILL LINE

[THERMOSTATIC HEATER]

WAYNE SELECT S1 DISPENSER

- DISPENSER CABINET:
- AUTO SHUTOFF NOZZLE
  - SWIVEL BREAKAWAY
  - [NOZZLE HEATER]

- HOSE REEL:
- SPRING REWIND
  - 20 FT HOSE LENGTH
  - [30/40 FT HOSE UPGRADE]

2" DRY-BREAK FILL ADAPTER

FREESTANDING TANK

SUBMERSIBLE PUMP

NOTE: OPTIONAL COMPONENTS ARE LISTED IN SQUARE BRACKETS [ ].



PROJECT		3RD PARTY W&M WIDE		
DWG.		PLUMBING & ELECTRICAL		REV
DWG. NO.	DRAWN	REV DATE	001	
SD-PLT-3WM-S2	TL	06/28/2022		
SCALE	SIZE	SHEET	2 OF 2	
NTS	A			